

法兰式直线轴承系列  
Flanged Linear Motion Ball Bearing Series

LMH...UU尼龙保持架  
该类型尺寸是公制的，广泛应用于亚洲和其他国家。

LMH...UU (Resin retainer)  
This type is a metric dimension series  
widely used in Asia and other  
countries.

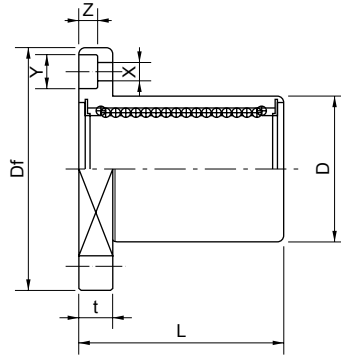

LMH...UU

公称轴径 Nominal shaft diameter mm	椭圆法兰 LMH...UU	重量 Weight (g)	主要尺寸和公差 Major dimensions and tolerance					
			dr		D		L	
			mm	公差 Tolerance μm	mm	公差 Tolerance μm	mm	公差 Tolerance μm
6	LMH6UU	21	6	0 -9	12	0 -11	19	± 300
8	LMH8UU	33	8		15	0 -13	24	
10	LMH10UU	64	10		19		29	
12	LMH12UU	68	12	21	30		0 -200	
13	LMH13UU	81	13	23	32			
16	LMH16UU	112	16	28	37			
20	LMH20UU	167	20	0 -10	32	0 -16	42	0 -300
25	LMH25UU	325	25		40		59	
30	LMH30UU	388	30		45		64	
35	LMH35UU	580	35	0 -12	52	0 -19	70	
40	LMH40UU	920	40		60		80	

注：所有LMH型均为双密封。  
Note: All sizes of LMH type are sealed on both sides.

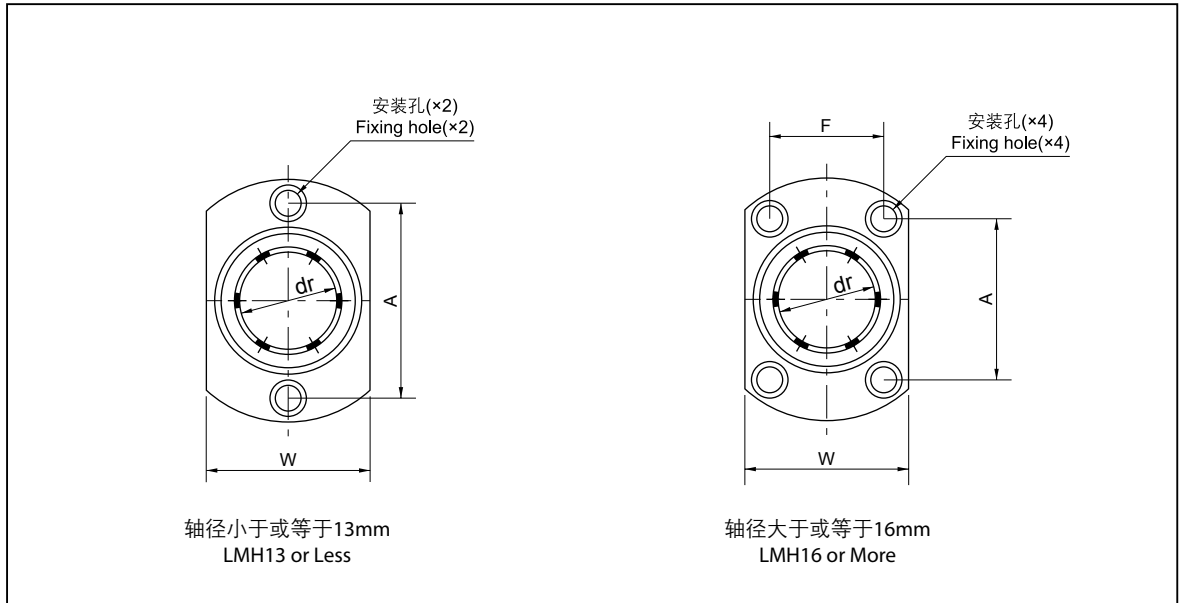

主要尺寸和公差 Major dimensions and tolerance								偏心 Eccentricity μm	垂直度 Squareness μm	额定负荷 Basic load rating	
法兰 Flange										动负荷 Dynamic CN	静负荷 Static Co N
Df mm	W mm	t mm	A mm	F mm	X mm	Y mm	Z mm				
28	18	5	20	-	3.5	6	3.1	12	12	206	265
32	21	5	24	-	3.5	6	3.1			274	392
40	25	6	29	-	4.5	7.5	4.1			372	549
42	27	6	32	-	4.5	7.5	4.1			510	784
43	29	6	33	-	4.5	7.5	4.1			510	784
48	34	6	31	22	4.5	7.5	4.1		774	1,180	
54	38	8	36	24	5.5	9	5.1	15	15	882	1,370
62	46	8	40	32	5.5	9	5.1			980	1,570
74	51	10	49	35	6.6	11	6.1			1,570	2,740
82	60	10	55	38	6.6	11	6.1	20	20	1,670	3,140
96	70	13	64	45	9	14	8.1			2,160	4,020

国际单位: 1N≈0.102kg  
SIUNIT: 1N≈0.102kg